

HVAC

CONDENSATE MANAGEMENT HI - H3



CLEANERS & CHEMICALS H5 - H6



COOLANT MANAGEMENT H7 - H8



LIQUID TITE & MISC H9 - H13



CP-22 Pumps



TCP-22

- Suitable for use with condensate from high efficiency condensing furnaces and boilers which produce acidic condensate
- 22" of lift compared to the typical 20"
- Vibration dampening feet & motor mounts
- Metal hang tabs
- Four inlet holes
- Clear indicator display
- Float switch
- Check valve
- 1/4" quick connect terminals provide easy connection to the built in overflow switch. 2 terminals are provided allowing flexibility to connect air handler shut down.
- UL Listed File Numbers E253155 and E258186.

CAT. NO.	DESCRIPTION	UOM	ORDER MULTIPLE
TCP-22	CONDENSATE PUMP - 120V	EA	1
TCP-22T	CONDENSATE PUMP - 120V W/20' 3/8" TUBE	EA	1
TCP-22-230	CONDENSATE PUMP - 230V	EA	1
TCP-22-230T	CONDENSATE PUMP - 230V W/20' 3/8" TUBE	EA	1

ClearVue™ Mini Ductless System Pump



TCVMINI

- Featuring super quiet operation
- Designed for ductless system installations
- Variable Speed and Lift
- Floatless Sensor™
- ETL Listed

CAT. NO.	DESCRIPTION	UOM	ORDER MULTIPLE
TCVMINI	CLEARVUE MINI - DUCTLESS SYSTEM PUMP	EA	1

General Purpose Pumps



TCP-16

- The DiversiTech CP-16 condensate pump is an economical alternative that's based off of the proven CP-22 design. More compact than the CP-22, it's designed to lift to a maximum of 16 feet. The CP-16 shares many of the great features of the CP-22
- Hang tabs
- Four inlet holes
- Float switch
- Overflow switch
- Check valve
- UL Listed File Numbers E253155 and E258186

CAT. NO.	DESCRIPTION	UOM	ORDER MULTIPLE
TCP-16	CONDENSATE PUMP 16' LIFT 120V	EA	1
TCP-16-230	CONDENSATE PUMP 16' LIFT 230V	EA	1

CP-22 Low Profile Pumps



TCP-22LP

- The new CP-22LP comes packed with all the same great features found in the CP-22, but now in a low profile package. This pump is only 4-3/8" tall so its a good fit for those instances where space is at a premium. The shorter reservoir holds 1/3 gallon.
- Hang tabs
- Four inlet holes
- Check valve
- Suitable for use with condensate up to 160°F
- UL Listed File Numbers E253155 and E258186

CAT. NO.	DESCRIPTION	UOM	ORDER MULTIPLE
TCP-22LP	CONDENSATE PUMP - 120V - LOW PROFILE	EA	1
TCP-22LP-230	CONDENSATE PUMP - 230V - LOW PROFILE	EA	1

Wet Switch Flood Detector Hockey Pucks

- A solid state control designed to help prevent flooding, damage to carpets, walls, furniture, ceilings, etc.
- Built in test and reset button for easier installation
- Turns system off when detecting moisture due to condensate or drain leaks. One or two drops will cause Wet Switch to turn off a unit, alerting a serviceman to a moisture problem
- Lit LED indicates the Wet Switch is activated and has turned the unit off
- Reset simply by drying the absorbent pad with a paper towel and pressing the reset switch
- Connects to 24 VAC
- More than one unit may be connected to a system
- 2 amp contact rating
- Simple 5 wire installation
- UL508 Approved
- ETL Listed File Number 3146992.



TWS-1

CAT. NO.	DESCRIPTION	UOM	ORDER MULTIPLE
TWS-1	WET SWITCH FLOOD DETECTOR	EA	1

CS-3 Condensate Pan Switch



TCS-3

The CS-3 is a clip-on pan switch that uses a magnetic reed switch for condensate overflow protection

- cULus Listed

CAT. NO.	DESCRIPTION	UOM	ORDER MULTIPLE
TCS-3	CONDENSATE SWITCH - CLIP	EA	1

LuxPro Thermostats



T675-PSDIII

- LuxPro thermostats are designed to be a reliable, simple solution to in home comfort, so that everyone can enjoy the benefits and comforts of advanced temperature control

CAT. NO.	DESCRIPTION	UOM	ORDER MULTIPLE
T675-PSDIOBF	DIGITAL FOR HEAT ONLY, WITH FAN SWITCH	EA	1
T675-PSDIII	IH /IC, NON-PROGRAMMABLE, VERTICAL/HORIZONTAL	EA	1
T675-PSDH2I	I OR 2 H/C, NON-PROGRAMMABLE, VERTICAL/HORIZONTAL	EA	1

Pipe Mounted Switches

DiversiTech Flood Prevention Switches are simple to install, easy to service and extremely reliable. As water level in the auxiliary or main drain pipe rises due to a clogged air conditioning condensate drain, the switch shuts off the system - thus preventing water from overflowing and causing damage to doors, walls and ceilings. At the heart of the switch is a durable yet precise magnetic reed switch. Constructed of materials that will not rust or stick, the switch operates smoothly every time. UL508 Approved, cULus Listed.



TCS-1

TCS-2

CAT. NO.	DESCRIPTION	UOM	ORDER MULTIPLE
TCS-1	CONDENSATE SWITCH - TEE	EA	1
TCS-2	CONDENSATE SWITCH - ELBOW	EA	1

Condensate Cop™

Condensate Cop™ is a unique clamp on float switch intended for HVAC drain pan installation. The Condensate Cop™ features a large over clamping area that fits easily over the edge of all types of drain pans; including formed plastic and galvanized sheet metal. A separate float/probe assembly swivels to accommodate drain pans having sloped sides. The swivel action allows the installer to position the float switch for best operation and then clamp it into place. The probe features an inlet grill which prevents the float from being blocked or damaged by insulation or other debris. Sealed inside the probe is a magnetically actuated normally closed switch. The switch opens when rising water presents a potential flooding condition.

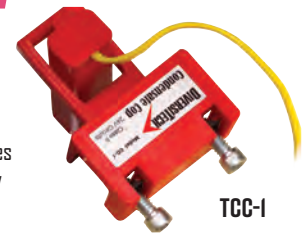

TCC-1

- Two wire connection for easy hook up to a thermostat "Y" (compressor) circuit
- 5' (1.5 meter) leads, wire nuts, and clamping screws
- Small size, 24V/1.5 amp NC reed switch
- ETL Listed File Number 3166285 UL508 Approved

CAT. NO.	DESCRIPTION	UOM	ORDER MULTIPLE
TCC-1	CONDENSATE COP™ DRAIN PAN SWITCH	EA	1

Plastic Thermostat Guards



T585-TGI

- Used to prevent tampering with thermostats
- Covers are clear, allowing complete view of the thermostat and current settings
- Includes vent holes for easy airflow across the thermostat
- Lockable with universal key
- Includes mounting screws and key

CAT. NO.	DESCRIPTION	T-STAT CLEARANC	UOM	ORDER MULTIPLE
T585-TG	CLEAR PLASTIC W/TWO BASES	8-1/4" X 4-1/2" X 3-1/4"	EA	1
T585-TGI	CLEAR PLASTIC W/TWO BASES	5-3/4" X 3-1/2" X 2-3/4"	EA	1
T585-TG6	CLEAR PLASTIC W/TWO BASES	6-1/4" X 3-3/4" X 1-3/4"	EA	1
T585-F336	KEY FOR THERMOSTAT GUARD		EA	1

Drain Gun™ - SWOOSH CO2 Cartridges



TGG-1

- Clears condensate drains with a SWOOSH!
- Lightweight (3 oz.) portable tool designed to blow out drain lines instantly
- New larger SWOOSH CO2 cartridges now deliver 800 PSI of oil free air to clear the line
- Each unit comes equipped with a tapered fitting to work on 3/8in. - 3/4in. drain openings
- Flexible hose assembly maneuvers through cabinets, coils and hard to reach drains
- Cartridges are environmentally safe and recyclable
- No need for air or nitrogen tanks
- Reduces labor costs and time on service calls

CAT. NO.	DESCRIPTION	UOM	ORDER MULTIPLE
TGG-1	DRAIN GUN™ FOR A/C CONDENSATE LINES	EA	1
TGGC-12	SWOOSH CO2 CARTRIDGES, PACK OF 12	PK	1
TGGC-12B	SWOOSH CO2 CARTRIDGES, BULK PACK OF 100	PK	1
TGGC-6	SWOOSH CO2 CARTRIDGES, PACK OF 6	PK	1

Compressor Repair Kit Cartridges



TLC-3-8

- Finally, a product that simplifies the repair of burned or damaged spade terminals when reconnecting or replacing a compressor. Fits both non burned and burned terminals. Connects to the compressor via precision brass cylinders that fit over the terminals and connect with stainless steel set screws. Standard factory 600V, 65 strand machine wire. Easy to install and guaranteed for the life of the compressor

CAT. NO.	DESCRIPTION	UOM	ORDER MULTIPLE
TTLC-3-8	3 WIRE, 8 GAUGE CONNECTION KIT	EA	1
TTLC-3-10	3 WIRE, 10 GAUGE CONNECTION KIT	EA	1
TTLC-3-12	3 WIRE, 12 GAUGE CONNECTION KIT	EA	1

Concentric Vents



TCVENT-3

TCVENT-2

- Concentric vents make it easier to have a two pipe installation for high efficiency furnaces
- These vents simplify installation and only require one hole through the wall or roof where the pipes terminate. Without using these vents, the installation would require cutting two holes through the home, one for each pipe
- These vents save time and money by reducing the amount of work required
- Available in 2" or 3" intake vent sizes
- Conform to ANSI/ASTM standards

CAT. NO.	DESCRIPTION	UOM	ORDER MULTIPLE
TCVENT-2	2" CONCENTRIC VENT	EA	1
TCVENT-3	3" CONCENTRIC VENT	EA	1
TCVENT-4	4" CONCENTRIC VENT	EA	1

Equipment Mounting Brackets - HVAC MINI-SPLIT STANDS

NEW

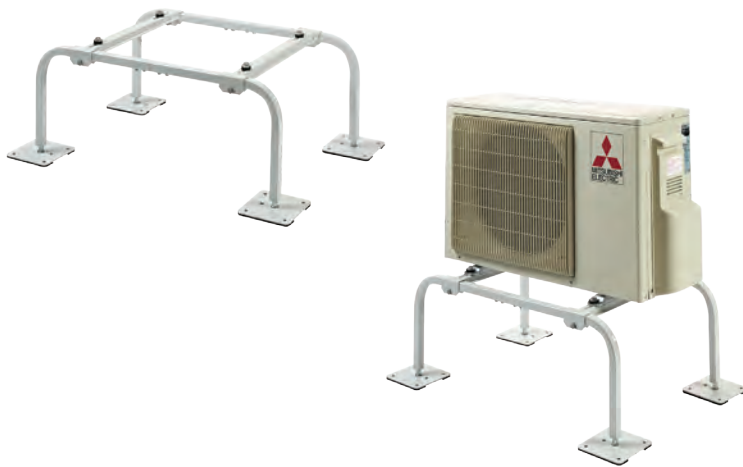

- 14 gauge square steel tubing
- Fits all mini split brands on the market
- 6" x 6" w/ 3/8" slotted feet
- Adjustable in height up to 1.25"
- 50 derometer pads on each foot
- Max capacity 400 lbs
- 4 points of anti-vibration isolation washers
- Adjustable footprint from 34" to 40" in 1" increments

CAT. NO.	SIZE	QTY	CASE QTY
TTQSMS120I	12"	1	25
TTQSMS180I	18"	1	25
TTQSMS240I	24"	1	25

Equipment Wall Mounting Brackets

NEW



- Width adjustable from 0" to 34" - 25" Shelf Depth
- Pre-Slotted for quick Connection to Unit
- 6 Points of anti-vibration isolation
- Engineered to reduce assembly by 50%
- Heavy Ga. Steel
- 350 Lb or 500 Lb Weight Capacity
- All necessary hardware included
- Hurricane Certified

CAT. NO.	WEIGHT	STEEL GA	CASE QTY
TTQSWB2000	350 LB	14	1
TTQSWB4000	500 LB	11	1

Equipment Ceiling Mounting Brackets

NEW



- Mounts parallel or across joists at 16" or 24" on center
- Allows for 360° unit rotation
- Direct flow of heat for maximum efficiency
- Safely locks into place after installation
- 200 lbs Max Capacity
- 14 Ga Steel
- Includes all necessary hardware

CAT. NO.	CASE QTY
TTQSWI3000	1

Triple-D™ Universal Coil Cleaner



TTRIPLE-D

- Universal coil cleaner that can be used on condensers, evaporators, microchannels, roof-top units, and mini-split applications
- Triple active synergistic highly effective solution is formulated to remove a broad range of soils while degreasing and deodorizing
- Ideal for cleaning most metals including aluminum and copper while extending equipment life and diminishing the potential for refrigerant leaks
- Using 75% less than comparable products, it reduces the amount of solution needed to clean
- Biodegradable and NSF approved.
- Available in seven different packaging configurations

CAT. NO.	DESCRIPTION	UOM	ORDER MULTIPLE
TTRIPLE-D	TRIPLE-D™ - 1 GALLON CONCENTRATE	EA	4
TTRIPLE-D-AER	TRIPLE-D™ - 19 OZ. AEROSOL	EA	12

Pro-Green™



TPRO-GREEN

- No rinse, mild alkaline coil cleaner
- Use on air-cooled condensers, evaporators, electronic and permanent filters, fan blades, grilles, mini-split and microchannel applications
- Cleans deposits on coils and ridges condensate pans of slime
- NSF approved for use in federally inspected plants

CAT. NO.	DESCRIPTION	UOM	ORDER MULTIPLE
TPRO-GREEN	PRO-GREEN™ NO RINSE (NON-TOXIC) - 1 GALLON CONTAINER	EA	4
TPRO-GREEN-AER	PRO-GREEN™ - 19OZ AEROSOL	EA	6

Pro-Brown™



TPRO-BROWN

- Heavy duty alkaline cleaner that pulls out deeply embedded dirt removing greasy soils and oxidation while brightening and cleaning coils.
- Ideal for air-cooled condensers, microchannels, and mini-splits thanks to its dual action foaming capabilities
- Biodegradable
- NSF approved

CAT. NO.	DESCRIPTION	UOM	ORDER MULTIPLE
TPRO-BROWN	PRO-BROWN™ FOAMING COIL CLEANER - 1 GALLON CONTAINER	EA	4
TPRO-BROWN AER	PRO-BROWN™ - 19OZ AEROSOL	EA	6

Pro-Blue™



TPRO-BLUE

- Heavy foaming alkaline-based solution designed for condensers, microchannels, and mini-splits
- Penetrates dirt and grease removing deposits resulting in clean and brightened coils
- Biodegradable
- NSF approved

CAT. NO.	DESCRIPTION	UOM	ORDER MULTIPLE
TPRO-BLUE	PRO-BLUE™ FOAMING CONCENTRATE (NON-ACID) - 1 GALLON CONTAINER	EA	4
TPRO-BLUE-AER	PRO-BLUE™ - 19OZ AEROSOL	EA	6

Eco-Coil™ Environmentally Friendly Coil Cleaner



TECO-COIL

- Environmentally friendly no rinse non-corrosive cleaner ideal for evaporator and condenser coils, electronic and permanent filters, fan blades, grilles, mini-split and microchannel applications
- Quickly cleans away dirt, dust, and deposits while deodorizing with no harmful risks to animal, aquatic or plant life
- Tested to provide the highest level of performance, Eco-Coil not only reduces the number of products required to clean but also has different water mixture ratios to maximize solution usage
- Brightens
- Biodegradable and NSF approved
- Meets the EPA's Design for the Environment Alternative Program as a "green" product

CAT. NO.	DESCRIPTION	UOM	ORDER MULTIPLE
TECO-COIL	ECO-COIL™ ENVIRONMENTALLY FRIENDLY COIL CLEANER - 1 GALLON CONTAINER	EA	4
TECO-COIL-AER	ECO-COIL™ - 19OZ AEROSOL	EA	6

Pro-Yellow™



TPRO-YELLOW

- Powerful cleaner.
- Ideal for condensers, microchannels, and mini-splits that targets large concentrations of dirt and grime.
- Heavy foaming alkaline-based solution.
- Debris will be removed from the coil while providing excellent brightening.
- Biodegradable
- NSF approved

CAT. NO.	DESCRIPTION	UOM	ORDER MULTIPLE
TPRO-YELLOW	PRO-YELLOW™ (NON-TOXIC) - 1 GALLON CONTAINER	EA	4
TPRO-YELLOW-AER	PRO-YELLOW™ - 19OZ AEROSOL	EA	6

Pro-Kleen™

- Unique foaming acid coil cleaner
- Designed to replace hazardous hydrofluoric acid coil cleaners
- Contains a synergistic combination of mineral acids, corrosion inhibitors, biodegradable surfactants, penetrants, and degreasers that emulsify, solubilize and neutralize soils leaving a clean, bright, efficient coil surface
- Easy-rinse formula removes a broad range of soils
- Does not contain dangerous hydrofluoric or bipotassium phosphate



TPRO-KLEEN

CAT. NO.	DESCRIPTION	UOM	ORDER MULTIPLE
TPRO-KLEEN	PRO-KLEEN™ OUTDOOR COIL CLEANER - 1 GALLON CONTAINER	EA	4

Saf-N-Kleen™ Aerosol Solvent Coil Cleaner

- High-solvency formula quickly and easily dissolves dirt, grease, oil or other residue while the blasting nozzle separates the materials from the surface
- Non-flammable, non-conductive formula is safe to use on live equipment



T357-20

CAT. NO.	DESCRIPTION	UOM	ORDER MULTIPLE
T357-20	SAF-N-KLEEN™ SOLVENT COIL CLEANER - 18 OZ. AEROSOL	EA	12

Pro-Flush® HVAC Flushing Solvent

- A flushing solvent for A/C and refrigeration systems
- Formulated for R410A retrofits, refrigerant conversions and compressor burnouts
- Compatible with all refrigerants and compressor oils
- All solvents in Pro-Flush® are non VOC and conform to EPA SNAP standards: low toxicity and residue free
- Available as a kit or 16 oz. solvent refill
- The kit makes servicing quick, easy, and safe, as well as assuring you get to the job site with all necessary hardware in hand for one stop servicing
- The kit includes: 8 oz. container of Pro-Flush® solvent, refillable Pro-Flush® injector tool pressure tank, pressure relief valve for added safety
- Large rubber adapter that flushes up to 1-1/4" line sets
- Service hose included

CAT. NO.	DESCRIPTION	UOM	ORDER MULTIPLE
TPF-KIT	PRO-FLUSH® KIT - INJECTOR, 8 OZ. REFILL, NOZZLE ADAPTER AND HOSE	EA	3
TPF-16	PRO-FLUSH® HVAC FLUSHING SOLVENT - 16 OZ. REFILL	EA	6

Pro-Red Plus™

- Fast acting cleaning solution.
- For condensers, microchannels, and mini-splits
- Foams and lifts away stubborn deposits including tarnish and corrosion
- Non-acid formula is as effective as conventional acid cleaners without the use of hydrofluoric acid
- Vigorous foaming action eliminates the need for prolonged soaking, steam cleaning or scrubbing coils without emitting corrosive fumes or rusting ferrous metals
- Biodegradable
- NSF approved



TPRO-RED+

CAT. NO.	DESCRIPTION	UOM	ORDER MULTIPLE
TPRO-RED+	PRO-RED PLUS™ CLEANER AND BRIGHTENER (NON-ACID) - 1 GALLON CONTAINER	EA	4
TPRO-RED+AER	PRO-RED PLUS™ - 19OZ AEROSOL	EA	6

Foam-Plus™ Aerosol Foaming Coil Cleaner

- Heavy-duty foaming detergent coil cleaner in an aerosol can
- Non-flammable and water-based with no chlorinated solvents
- Blasting foam stream reaches into tight areas for maximum cleaning
- Foaming alkaline detergent quickly liquifies dirt, grease, oil or other residue and is completely self-rinsing on condensate producing coils



T358-20

CAT. NO.	DESCRIPTION	UOM	ORDER MULTIPLE
T358-20	FOAM-PLUS™ FOAMING COIL CLEANER - 19 OZ.	EA	12



PF-KIT

Super Change™



T20I22

- Super Change™ eliminates oil change outs replacing R22 line set conversion flushes.
- Ideal for dry charged units, retrofits, and drop-in refrigerants.
- Maximizes oil return and heat transfer including PDE charged compressors.

CAT. NO.	DESCRIPTION	UOM	ORDER MULTIPLE
T98I	SUPER CHANGETM - UP TO 6 TONS	EA	6
T20I22	REUSABLE CHARGING HOSE FOR SUPER CHANGETM	EA	1

Pro-Bubble™ Leak Detector



- Easy-to-use.
- High bubbling.
- Viscoelastic blue leak detector.

CAT. NO.	DESCRIPTION	UOM	ORDER MULTIPLE
TPROBUBBLE-32	PRO-BUBBLE™ LEAK DETECTOR - 32 OZ. BOTTLE WITH SPRAY TOP	EA	12

TPROBUBBLE-32

Flash™ UV Leak Detection Kit



T98084KIT

- Flash™ UV leak detection kit includes 3 cans of Flash™ dye, a reusable clear hose, heavy-duty storage case, and SEEKERmini™ Worklight

CAT. NO.	DESCRIPTION	UOM	ORDER MULTIPLE
T98084KIT	FLASH™ WITH 3 CANS, HOSE AND SEEKERMINI™ WORKLIGHT	EA	1

PAN-PATCH™



TPANPATCH

- Pan-Patch™ is a two part epoxy coating with anti-microbial additives designed for HVAC applications. A self leveling formula that is ideal in a damp or wet environment.
- Resists corrosion and stops pan leaks without replacing the pan.
- Light gray in color
- One gallon covers about 160 square feet with 10 mil thickness.

CAT. NO.	DESCRIPTION	UOM	ORDER MULTIPLE
TPANPATCH	PAN-PATCH™ PAN SEALANT - 1 GALLON	EA	4

Duct Seal "DiversiGum"



- Non-hardening.
- For plugging openings through foundations or around refrigeration tube entry.

CAT. NO.	DESCRIPTION	UOM	ORDER MULTIPLE
T6-202-I	DUCT SEAL "DIVERSIGUM" - 1 LB. SLUG	EA	1

Pro-Air Duct Sealant - UL 181 AM-BM Listed



T800-009

- Water-based fiber-reinforced duct sealant/mastic formulated for indoor/outdoor use.
- Meets U.L. Class I rating and local code while featuring long term flexibility and strength.
- Use on metal heating, ventilating, and A/C duct systems; as well as fiberglass duct board systems and flex duct systems.
- Recommended for use to 10" of water column pressure without the need for fiberglass mesh reinforcement.

CAT. NO.	DESCRIPTION	UOM	ORDER MULTIPLE
T800-009	PRO-AIR DUCT SEALANT - 1 GALLON PAIL	EA	1

Super Seal Advanced™

- Super Seal Advanced includes a stop leak sealant and Dry R
- Provides for a fast install with no pump down or recovery even for R410A
- Compatible with all oils and refrigerants
- Hose included



T944KIT

CAT. NO.	DESCRIPTION	UOM	ORDER MULTIPLE
T947KIT	SUPER SEAL ADVANCED™ - UP TO 1.5 TONS	EA	12
T944KIT	SUPER SEAL ADVANCED™ - 1.5 TO 5 TONS	EA	12
T948KIT	SUPER SEAL ADVANCED™ - 5+ TONS	EA	12

Super Seal Total™

- Provides for a fast install with no pump down or recovery
- Compatible with all oils and refrigerants



T972KIT

CAT. NO.	DESCRIPTION	UOM	ORDER MULTIPLE
T971KIT	SUPER SEAL TOTAL™ - UP TO 1.5 TONS	EA	12
T972KIT	SUPER SEAL TOTAL™ - 1.5 TO 5 TONS	EA	12

Seal-N-Go® Self-Sealing Refrigerant

- Seal-N-Go™ makes charging 410A systems faster and easier than ever. It's a portable, easy to handle, self-sealing refrigerant that permanently seals & prevents leaks
- Light-weight, compact, and portable
- Ideal for topping off multiple systems, including mini-split installs.
- Permanently seals and prevents leaks while eliminating moisture.



T941OSSR

CAT. NO.	DESCRIPTION	UOM	ORDER MULTIPLE
T941OSSR	SEAL-N-GO® 25.7 R410 REFRIGERANT PLUS SUPER SEAL ADVANCED™	EA	6

Super Seal Flex Inject®

- Super Seal Flex Inject™ is the fastest, most effective proven way to permanently seal and prevent minor air conditioning and refrigeration (AC/R) leaks. With no tools or gauges required, the Flex Inject sealant works by travelling through the system with the oil and refrigerant fixing leaks immediately.
- Works with all compressors, heat pumps, condensers, and other system components.
- Meets the ASHRAE ARI 700 refrigerant standard.
- Suitable for use in aluminum and copper coils.



T972KIT

CAT. NO.	DESCRIPTION	UOM	ORDER MULTIPLE
T985	SUPER SEAL FLEX INJECT™	EA	1

Super Seal Sure Shot™

- Compressor-friendly method of permanently sealing leaks in AC/R systems.
- Reduces noise and energy consumption.
- Enhances sealant performance.
- Hose and cartridge included.



T983KIT

CAT. NO.	DESCRIPTION	UOM	ORDER MULTIPLE
T983KIT	SUPER SEAL SURE SHOT™ - UP TO 6 TONS	EA	12
T984	SUPER SEAL SURE SHOT™ REPLACEMENT CARTRIDGE - UP TO 6 TONS	EA	12

HVAC PRODUCTS
 Coolant Management

Hose Clamps



TB-32H

- Stainless steel housings and bands.
- The screws are plated steel and have slotted hex heads allowing a socket wrench, nut driver, or screwdriver to be used.

CAT. NO.	DESCRIPTION	UOM	ORDER MULTIPLE
TB-4H	NO. 4, 7/32" - 5/8" DIA., 3/16" - 5/16" HOSE I.D.	EA	10
TB-6H	NO. 6, 3/8" - 7/8" DIA., 1/4" - 3/8" HOSE I.D.	EA	10
TB-8H	NO. 8, 7/16" - 1" DIA., 5/16" - 1/2" HOSE I.D.	EA	10
TB-10H	NO. 10, 9/16" - 1-1/16" DIA., 3/8" - 5/8" HOSE I.D.	EA	10
TB-12H	NO. 12, 9/16" - 1-1/4" DIA., 5/8" - 3/4" HOSE I.D.	EA	10
TB-16H	NO. 16, 11/16" - 1-1/2" DIA., 3/4" - 1" HOSE I.D.	EA	10
TB-20H	NO. 20, 3/4" - 1-3/4" DIA., 1" - 1-1/4" HOSE I.D.	EA	10
TB-24H	NO. 24, 1-1/16" - 2" DIA., 1-1/4" - 1-1/2" HOSE I.D.	EA	10
TB-28H	NO. 28, 1-5/16" - 2-1/4" DIA., 1-1/4" - 1-3/4" HOSE I.D.	EA	10
TB-32H	NO. 32, 1-9/16" - 2-1/2" DIA., 1-1/2" - 2" HOSE I.D.	EA	10
TB-36H	NO. 36, 1-13/16" - 2-3/4" DIA., 1-3/4" - 2-1/4" HOSE I.D.	EA	10

One Piece Heat Pump Risers



THPR-6

- Sturdy and stable, DiversiTech's Heat Pump Riser provides the desired elevation for condensers, heat pumps, and air handlers.
- The one piece, heavy duty plastic unit is manufactured in three heights.
- Butyl mastic on the top and bottom guarantees no slipping and reduced vibration and noise.

CAT. NO.	DESCRIPTION	UOM	ORDER MULTIPLE
THPR-3	RISER - 3"	EA	1
THPR-6	RISER - 6"	EA	1
THPR-12	RISER - 12"	EA	1

Duct Strap - Woven Polypropylene



T710-100

- Webbed duct strap possessing high tensile and abrasion resistance.
- Can be used for flex duct as it is easy to cut and staple to joists.
- Chemical resistant.
- Listed to spec 2040.
- UL Listed

CAT. NO.	DESCRIPTION	UOM	ORDER MULTIPLE
T710-100	DUCT STRAP - 1-3/4" X 100 YARDS - BLACK	EA	1
T710-102	DUCT STRAP - 3" X 100 YARDS - BLACK	EA	1

Manifold Gauge

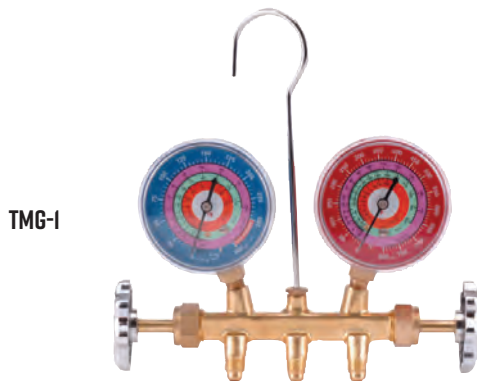

TMG-1

DiversiTech's MG-1 Manifold Gauge provides the technician with a precision diagnostic and monitoring analog gauge set complete with hoses.

- The Manifold Gauge and Hose Set includes:
 - 2 valve brass manifold
 - 5' long high pressure hose set
- For use with the following refrigerants:
 - R-410A
 - R-22
 - R-407C
- Detailed gauge readings in PSI °F

CAT. NO.	DESCRIPTION	UOM	ORDER MULTIPLE
TMG-1	MANIFOLD GAUGE AND HOSE SET	EA	1

Wolverine[®] Universal Hot Surface Igniter

- Silicon Nitride Igniter
- Wolverine[®] hot surface igniters are 100% tested and completely reliable.
- They are compatible with all OEM furnaces.
- Universal hot surface igniters allow a contractor to reduce truck stock and replace hundreds of OEM igniters with just one SKU.
- CSA Certified

CAT. NO.	DESCRIPTION	UOM	ORDER MULTIPLE
TIGN-2	WOLVERINE HOT SURFACE IGNITER BY TRUESTART, UNIVERSAL, SILICON NITRIDE	EA	1



TIGN-2

Direct Replacement Igniters

- Silicon Carbide Igniter
- TrueStart[™] hot surface igniters are 100% tested and completely reliable.
- They are compatible with all OEM furnaces.
- cULus Listed

CAT. NO.	DESCRIPTION	UOM	ORDER MULTIPLE
TIGN-401	TRUESTART [™] HOT SURFACE IGNITER, DIRECT REPLACEMENT, SILICON CARBIDE, .84" PINS	EA	1
TIGN-409	TRUESTART [™] HOT SURFACE IGNITER, DIRECT REPLACEMENT, SILICON CARBIDE, .92" PINS	EA	1



TIGN-401

Universal Silicon Carbide Igniter

- Silicon Carbide Igniter
- TrueStart[™] hot surface igniters are 100% tested and completely reliable.
- They are compatible with all OEM furnaces.
- TrueStart[™] hot surface igniters are available as a universal silicon carbide igniter.
- cULus Listed

CAT. NO.	DESCRIPTION	UOM	ORDER MULTIPLE
TIGN-001	TRUESTART [™] HOT SURFACE IGNITER, UNIVERSAL, SILICON CARBIDE	EA	1



TIGN-001



Thermostat Wire



T620-18-5

- Class 2 thermostat wire for indoor wiring.
- Soft drawn bare copper wire.
- Semi rigid PVC insulation.
- PVC overall jacket.
- Packaged on aluminum spool.
- Meets Subject 13 per Article 725, 1990 NEC.
- U.L. Listed.

CAT. NO.	DESCRIPTION	UOM	ORDER MULTIPLE
T620-18-2	18 AWG, 2 CONDUCTORS - 500 FT. SPOOL	EA	1
T620-18-3	18 AWG, 3 CONDUCTORS - 500 FT. SPOOL	EA	1
T620-18-4	18 AWG, 4 CONDUCTORS - 250 FT. SPOOL	EA	1
T620-18-5	18 AWG, 5 CONDUCTORS - 250 FT. SPOOL	EA	1
T620-18-6	18 AWG, 6 CONDUCTORS - 250 FT. SPOOL	EA	1
T620-18-7	18 AWG, 7 CONDUCTORS - 250 FT. SPOOL	EA	1
T620-18-8	18 AWG, 8 CONDUCTORS - 250 FT. SPOOL	EA	1
T620-18-10	18 AWG, 10 CONDUCTORS - 250 FT. SPOOL	EA	1
T620-20-2	20 AWG, 2 CONDUCTORS - 500 FT. SPOOL	EA	1
T620-20-3	20 AWG, 3 CONDUCTORS - 500 FT. SPOOL	EA	1
T620-20-4	20 AWG, 4 CONDUCTORS - 250 FT. SPOOL	EA	1
T620-20-8	20 AWG, 8 CONDUCTORS - 250 FT. SPOOL	EA	1

High Temperature Wire, 400°F (204°C), 600 V.



- 7 strand tin coated copper wire.
- Silicone rubber insulation.
- Braided fiberglass jacket.
- Use on the front of all gas furnaces with spark ignition because of flame roll out on start up.
- Also on all power feeds to electric strip and duct heaters.
- Also used on all heat producing food preparation equipment.
- U.L. Listed.

CAT. NO.	DESCRIPTION	UOM	ORDER MULTIPLE
TWHTB14-50	14 GAUGE, BLACK, 50 FT.	EA	1
TWHTR14-50	14 GAUGE, RED, 50 FT.	EA	1
TWHTW14-50	14 GAUGE, WHITE, 50 FT.	EA	1
TWHTB12-50	12 GAUGE, BLACK, 50 FT.	EA	1
TWHTB10-20	10 GAUGE, BLACK, 20 FT.	EA	1
TWHTB10-50	10 GAUGE, BLACK, 50 FT.	EA	1

LiquidTite Flexible Conduit



- Type B Non-metallic liquidtight conduit
- For outside, inside and industrial uses
- Motor & Controls Installations
- HVAC Applications
- Power Distribution to Equipment
- Machine Tool Applications
- Transformer Terminations
- Outdoor lighting Applications
- Joins with metallic or non-metallic connectors
- 176° (80°C) Rated
- U.L. and C.U.L. Listed
- Nonconductive and noncorrosive
- Lightweight for easy handling, transportation, and installation
- Resistant to oil, acid, ozone, and alkaline
- Crush, abrasion, and strain resistant
- Smooth interior ideal for pulling cable
- Easy to cut into lengths, no jagged edges
- Maintains internal I.D. even in tight radius bends
- UL Listed for use as indicated in Article 351 of the 1987 NEC and Section 12-1300 of the 2002 Canadian Electrical Code, Part I
- UL Listed for outdoor use
- UV resistant



T750-12100

CAT. NO.	DESCRIPTION	UOM	ORDER MULTIPLE
T750-12100	1/2" X 100' LIQUID TITE CONDUIT - NON-METALLIC, 100' PER ROLL	EA	1
T750-12100 BOX	1/2" X 100' LIQUID TITE CONDUIT - NON-METALLIC, 100' PER ROLL IN BOX	EA	1
T750-121000*	1/2" X 1000' LIQUID TITE CONDUIT - NON-METALLIC, 1000' PER ROLL	EA	1
T750-34100	3/4" X 100' LIQUID TITE CONDUIT - NON-METALLIC, 100' PER ROLL	EA	1
T750-34800*	3/4" X 800' LIQUID TITE CONDUIT - NON-METALLIC, 800' PER ROLL	EA	1
T750-10100	1" X 100' LIQUID TITE CONDUIT - NON-METALLIC, 100' PER ROLL	EA	1
T750-10500*	1" X 500' LIQUID TITE CONDUIT - NON-METALLIC 500' PER ROLL	EA	1
T750-125100	1-1/4" X 100' LIQUID TITE CONDUIT - NON-METALLIC, 100' PER ROLL	EA	1
T750-1550	1-1/2" X 50' LIQUID TITE CONDUIT - NON-METALLIC, 50' PER ROLL	EA	1
T750-2050*	2" X 50' LIQUID TITE CONDUIT - NON-METALLIC, 50' PER ROLL	EA	1

* Must Ship LTL Freight; \$2,000 Order to qualify for freight allowed

DiversiWhips



T6-12-4

CAT. NO.	DESCRIPTION	UOM	ORDER MULTIPLE
T6-12-4	1/2 X 4' #10 THHN WIRE - METALLIC CONNECTORS	EA	1
T6-12-6	1/2 X 6' #10 THHN WIRE - METALLIC CONNECTORS	EA	1
T6-34-4	3/4 X 4' #8 THHN WIRE - METALLIC CONNECTORS	EA	1
T6-34-6	3/4 X 6' #8 THHN WIRE - METALLIC CONNECTORS	EA	1
T6-12-4NM	1/2 X 4' #10 THHN WIRE - NON-METALLIC CONNECTORS	EA	1
T6-12-6NM	1/2 X 6' #10 THHN WIRE - NON-METALLIC CONNECTORS	EA	1
T6-34-4NM	3/4 X 4' #8 THHN WIRE - NON-METALLIC CONNECTORS	EA	1
T6-34-6NM	3/4 X 6' #8 THHN WIRE - NON-METALLIC CONNECTORS	EA	1

- Liquid tight flexible conduit system.
- A labor saving convenience kit for A/C unit hookup.
- Also use for heat pumps, refrigeration, hot tubs, swimming pools and outdoor lighting
- Three distinct wire colors for ease of hook up
- One (1) straight and one (1) 90° metallic or non-metallic connector
- 90° connector is removable for straight connections
- (Second straight connector not included.)
- U.L. and C.U.L. Listed
- Bagged for Pegboard Display Hanging

DiversiWhips Pallet Packs



TB6-12-4NM

CAT. NO.	DESCRIPTION	UOM	ORDER MULTIPLE
TB6-12-4NM*	1/2 X 4' #10 THHN WIRE - NON-METALLIC CONNECTORS	EA	90
TB6-12-6NM*	1/2 X 6' #10 THHN WIRE - NON-METALLIC CONNECTORS	EA	60
TB6-34-6NM*	3/4 X 6' #8 THHN WIRE - NON-METALLIC CONNECTORS	EA	45

* Must Ship LTL Freight; \$2,000 Order to qualify for freight allowed

- DiversiWhips are now available in a convenient, bulk packaged pallet pack at a discounted price
- (1) straight and (1) 90 degree non-metallic connector

LiquidTite Connectors



T750-NMLT50



T750-NMLT9050

- For use with metallic and non metallic liquid tite conduit, Type B
- Provides smooth connection
- No sharp edges to damage wire
- Wire easily pulled through
- U. L. Listed, C.U.L. Listed

DIMENSIONS = INCHES

CAT. NO.	DESCRIPTION	UOM	ORDER MULTIPLE
	NON-METALLIC	EA	1
T750-NMLT50	1/2" NON-METALLIC STRAIGHT CONNECTOR	EA	1
T750-NMLT75	3/4" NON-METALLIC STRAIGHT CONNECTOR	EA	1
T750-NMLT9050	1/2" NON-METALLIC 90 DEGREE ELBOW CONNECTOR	EA	1
T750-NMLT9075	3/4" NON-METALLIC 90 DEGREE ELBOW CONNECTOR	EA	1

Single Piece LiquidTite Fittings



T750-SLTC50



T750-SLTC9050

- Conduit threads onto ferrule and up inside the outer body
- Inside taper squeezes down on conduit for superior liquid tight seal
- Cut portion of conduit does not show, giving a more finished appearance
- Easy to use at a lower cost than regular liquid tite fittings
- U.L. and C.U.L. Listed

DIMENSIONS = INCHES

CAT. NO.	DESCRIPTION	UOM	ORDER MULTIPLE
T750-SLTC50	1/2" STRAIGHT SCREW-ON FITTING	EA	1
T750-SLTC9050	1/2" 90° SCREW-ON FITTING	EA	1
T750-SLTC75	3/4" STRAIGHT SCREW-ON FITTING	EA	1
T750-SLTC9075	3/4" 90° SCREW-ON FITTING	EA	1

Non-Metallic LiquidTite Connectors - Straight

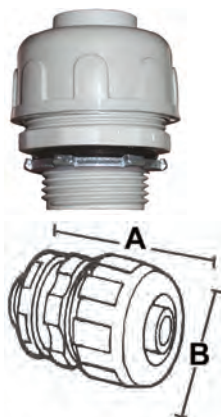

- Terminate and Seal Non-Metallic Liquid-tight Conduit
- Nylon Construction with Zinc Die-Cast Locknut
- UV Resistant

DIMENSIONS = INCHES

CAT. NO.	TRADE SIZE	DIMENSIONS		INNER BOX	OUTER BOX
		A	B		
21813	1/2"	2.11	1.43	25	150
21814	3/4"	2.30	1.70	10	100
21815	1"	2.26	1.91	5	50
21816	1-1/4"	2.70	2.40	5	50
21817	1-1/2"	2.76	2.70	4	40
21818	2"	2.81	3.39	2	20

Non-Metallic LiquidTite Connectors - 90°

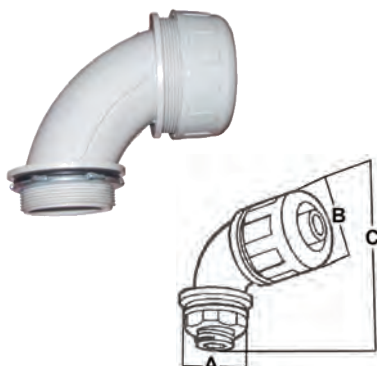

- 90° Orientation
- Terminate and Seal Non-Metallic liquid-tight Conduit
- Nylon Construction with Zinc Die-Cast Locknut
- UV Resistant

DIMENSIONS = INCHES

CAT. NO.	TRADE SIZE	DIMENSIONS			INNER BOX	OUTER BOX
		A	B	C		
21823	1/2"	.80	1.43	2.39	25	150
21824	3/4"	1.00	1.70	2.52	10	100
21825	1"	1.28	1.91	2.74	5	50
21826	1-1/4"	1.64	2.40	4.31	3	30
21827	1-1/2"	1.88	2.70	4.55	2	20
21828	2"	2.37	3.39	4.88	1	10